



MERITOR

In this Issue: Product In Focus • New Products • Supersessions • Tech Tips • Staff Profile

PRODUCT IN FOCUS - Euclid Gladhands

WHAT ARE GLADHANDS?

Gladhands are coupling devices used to connect the service and emergency air lines from the truck or tractor to the trailer. The couplers have a rubber seal which prevents air from escaping. To connect the gladhands, the driver presses the two seals together with the couplers at a 90° angle to each other. A turn of the glad hand attached to the hose will join and lock the couplers.

FEATURES AND BENEFITS:

- Providing secure, airtight connection
- Colour coded and clearly stamped for ease of identification (Blue – Service, Red – Emergency)
- Lightweight die cast aluminium body
- Includes black rubber seals
- Meets SAE J318 specifications
- Ordered in convenient and sturdy Euclid display buckets (when sold as 75 pieces)



Gladhand Bucket

GLADHANDS AND SEALS REFERENCE

EUCLID PART NUMBER	DESCRIPTION	IMAGE	REMARKS
E-9107-PL	SERVICE GLADHAND (BLUE)		BONUS BUCKET IN ORDER OF 75 UNITS
E-9108-PL	EMERGENCY GLADHAND (RED)		BONUS BUCKET IN ORDER OF 75 UNITS
E-9110	RUBBER GLADHAND SEAL		STANDARD
E-9111	RUBBER GLADHAND SEAL		INCLUDES EXCLUDER FLAPS

BULLS EYE 2018

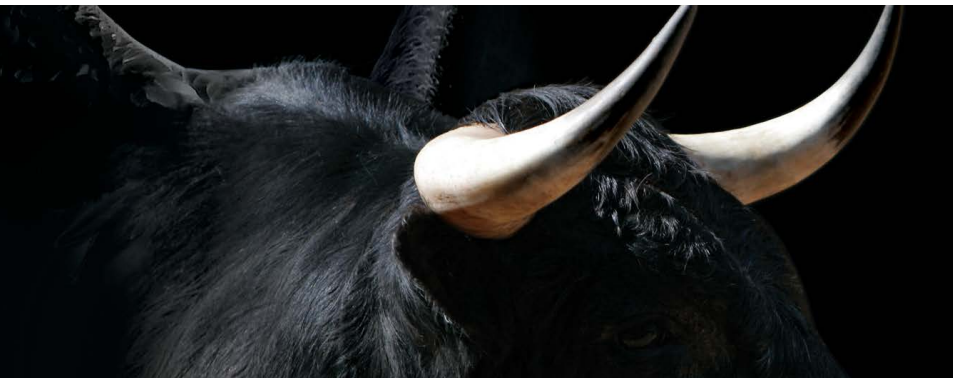

NEW PRODUCTS & SUPERSESSIONS

NEW PRODUCTS

Part Number	Description
A414621	GEARSET R140/ 145 6.83 RATIO
A283275S1059	AUTO SLACK ADJUSTER 5.5 1.50-28
R250067	SUSPENSION DRAG LINK
MERKIT007	WHEEL BEARING & SEAL KIT
09002166	RING ABS POLE
A23711X1116	AIR BRAKE SPIDER ASSY
A23711Y1117	AIR BRAKE SPIDER ASSY
KIT225021	KIT DISC PAD
R806022A	SLACK ADJUSTER AUTO 1 1/2 10SP 5 1/2-6 1/2
R955T224N	CARTRIDGE CR
KIT2951	GEARSET

SUPERSESSIONS

Old Part Number	Description	New Part Number
2237N14A	BRACKET ABS SENSOR	2237J1440

All parts displayed in New Products & Supersessions will be available for immediate ordering. Lead times apply for the listed items. Not all parts are available to Independent Customers. Please contact Meritor Customer Service on (03) 8353 6050 for further information. For full list of supersessions, [CLICK HERE](#)



BRAKE JOB CRITICAL-REVIEW COMPONENTS

Brake Drums

- The maximum allowable brake drum diameter is stamped or cast into the outer edge of the drum. Place a brake drum diameter gauge inside the drum. Take several measurements within 90 degrees of each other at the open and closed edges of the drum's friction surface

- If any of these measurements are 0.120-inch, replace the brake drum
- If a brake drum is out-of-round, replace the drum

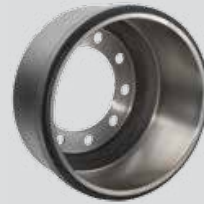

Slack Adjusters

- Verify the retaining bolt or snap ring is correctly secured in the camshaft
- Check slack adjuster gear torque – use a lb-in torque wrench and turn adjusting nut counterclockwise
 - If the torque value is less than 45 lb-in as you rotate gear, slack adjuster is operating correctly
 - If the torque value exceeds 45 lb-in as you rotate gear, replace slack adjuster



Shoes/Linings

- Measure lining wear. Linings must have a greater than ¼" thickness at the center of the brake lining. Inspect for cracks, separation from the brake shoe table, and loose rivets
- Always use new brake shoe hardware – rollers, roller retainers and return springs
- Inspect camshafts and camshaft bushings for wear
- RSD brake assemblies must be serviced with RSD brake shoe and lining assemblies to maintain braking capability. Use of non-RSD friction material could negatively impact the safe operation of the vehicle
- Replace all wheel seals



TECH TIPS

Includes:

- Brake Drums
- Slack Adjusters
- Shoes/Linings
- Brake Chambers
- Camshafts



Brake Chamber

- Check brake chamber for looseness or damage
- Ensure retaining nuts are tightened to specification
- Verify push rod is exiting the chamber at a 90 degree angle and it returns completely after each brake application
- Verify chamber size (20, 24, 30 etc.) and the chamber type – either standard or long stroke – are the same on each side of axle
- Inspect the chamber bracket for cracks and damage
- Verify the caging bolt, nut and washer are installed, and the caging bolt cover is secure

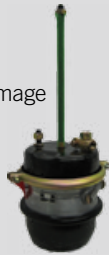

Camshafts

- Before removal of the automatic slack adjuster and camshaft, verify that cam-to-bushing radial free play is within spec
- Check the camshaft for cracks, wear or corrosion. Check the cam head bearing journals and splines. Replace worn or damaged camshafts. Install new bushings and seals whenever you install a new camshaft
- The bushing wears in one direction; it is important to rotate the camshaft in all directions when checking for radial free play
 - If radial free play is less than 0.030" (0.76mm) – do not replace bushing and seals
 - If radial free play is more than 0.030" (0.76mm) – replace bushings and seals



CAM BRAKE TORQUE SPECIFICATIONS

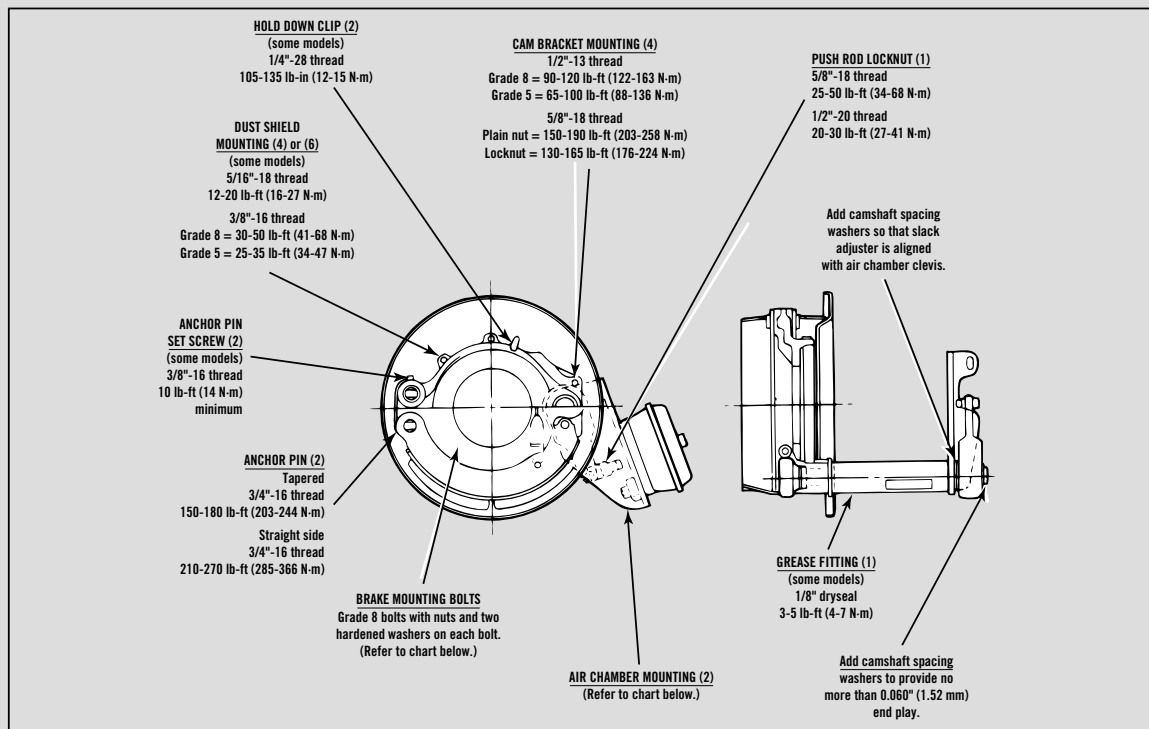



EMPLOYEE PROFILE - GORDANA MILOSESKA



***Role at Meritor:
Demand Planner***

Year Joined: 2014

What is your background in Demand Planning?

I started my career in Supply Chain 17 years ago. I spent the first 10 years of my career working for Autoliv Australia where I was fortunate to work across many areas of the business such as; Material Planner, Customer Service Liaison Officer, Divisional Officer, Warehouse Manager, Demand Planner, Production Scheduler and Senior Supply and Demand Planner. In 2011, I was offered a position at Continental as a Senior Supply Chain Analyst where I was in charge of Demand Planning and Inventory control. This position gave me the opportunity to further enhance my knowledge and passion for Demand Planning. In 2014, I accepted a job at Meritor Australia as a Demand Planner to take care of the forecasting activities associated with customers and products.

What challenges are involved in the role?

Inventory forecasting and demand planning play an important role in any business as it involves predicting the demand and sales patterns for various product groups. This ensures that stock is maintained at optimum levels without over incurring costs due to too much inventory while also not running into stock outs situations.

What interests do you have outside work?

I enjoy reading, traveling and learning new things. I can honestly say that I learn something new every day. Ongoing learning is a key aspect of my life and is crucial to my development as an individual and a professional. I find it to be one of the most rewarding aspects in life.