

# Aftermarket Product Bulletin



**MERITOR**

September 2014

## NEW PRODUCTS

Part Number	Description	List Price **
21230663	Rubber Bumper	\$119.49
MCK1146	Carrier Kit D ELSA 2 Trailer	\$320.82
MCK1252	Carrier Kit ELSA195 Trailer	\$199.56
E-8582-18-BK	1/2" Air Hose Assembly, 3/8" Ends - 18" Long	\$27.80
E-8582-20-BK	1/2" Air Hose Assembly, 3/8" Ends - 20" Long	\$27.80
E-8582-22-BK	1/2" Air Hose Assembly, 3/8" Ends - 22" Long	\$27.80
E-8582-24-BK	1/2" Air Hose Assembly, 3/8" Ends - 24" Long	\$27.80
E-8582-26-BK	1/2" Air Hose Assembly, 3/8" Ends - 26" Long	\$30.17
E-8582-28-BK	1/2" Air Hose Assembly, 3/8" Ends - 28" Long	\$30.17
E-8582-30-BK	1/2" Air Hose Assembly, 3/8" Ends - 30" Long	\$30.17
E-8582-32-BK	1/2" Air Hose Assembly, 3/8" Ends - 32" Long	\$30.17
E-8582-34-BK	1/2" Air Hose Assembly, 3/8" Ends - 34" Long	\$34.84
E-8582-36-BK	1/2" Air Hose Assembly, 3/8" Ends - 36" Long	\$34.84
E-8582-42-BK	1/2" Air Hose Assembly, 3/8" Ends - 42" Long	\$34.84
E-8582-48-BK	1/2" Air Hose Assembly, 3/8" Ends - 48" Long	\$34.84
E-8703	Air Hose Rack - Display Rack. Holds 48 Air Hose Assys	\$546.91

## SUPERSESSIONS

Old Part Number	Description	New Part Number	List Price **
A1225Q43A	Bushing	A1225Q1629	\$39.94
20RHM016B182H	Drive Shaft Inner Axle	20RHM085B180H	\$3,835.32
A406741	Gearset SHT 5.29	A406741529	\$2,607.36
20RY605	Yoke Weld RPL	20RY607	\$162.12

Please visit [http://meritorpartsonline.com.au/Documents/PartsBulletins/Supersessions/supersessions\\_september2014.pdf](http://meritorpartsonline.com.au/Documents/PartsBulletins/Supersessions/supersessions_september2014.pdf)

All parts displayed above will be available for immediate ordering. Lead times may apply.

Not all parts are available to Independent Customers. Please contact Meritor Customer Service for availability.

\*\*All list prices are correct at time of printing and subject to change.

# Aftermarket Getting Technical



**MERITOR**

September 2014

## Universal Joints

In the next three editions of the product bulletin, we will discuss a very important component of the driveline construction: Uni Joints. Following editions will cover identification and causes of uni joint problems and other forms of wear that can seriously compromise the vehicle and safety. We will also provide information on structural damage and finally working and driving conditions plus driveline vibrations that can contribute to uni joint wear and tear.

### Covering The Basics

By quickly covering the basics of U-joints and their common parts terms, you'll find the technical material covered in this edition will be much easier to understand and remember. For a brief review, let's first mention the purpose of driveshafts. We can sum it up by saying that their sole function is to transmit power from the transmission to the driving axles. Of course it must also change length as the truck's suspension moves according to road surface conditions. Many large trucks use more than just one shaft, especially those equipped with a long wheelbase and others with tandem rear axles. At each end of a drive-shaft (or coupling shaft), U-joints are required since the driving axle (or axles) is forced up and down as the wheels roll over bumps, large cracks and pot holes. Without the flexibility that U-joints provide, shafts would soon break from flexing fatigue. Splined slip yokes are also needed to permit smooth 'before and after' movement of shafts whenever the rear axle moves up and down. For the splines to move easily, without 'binding' they must be lubricated by a specific high-pressure and high-temperature type of grease.

**Note:** Lubrication of U-joints requires a good quality grease with Extreme Pressure Additives (EP) and high temperature capability. U-joint cups, bearings, and other parts of the assembly are shown in the image below:

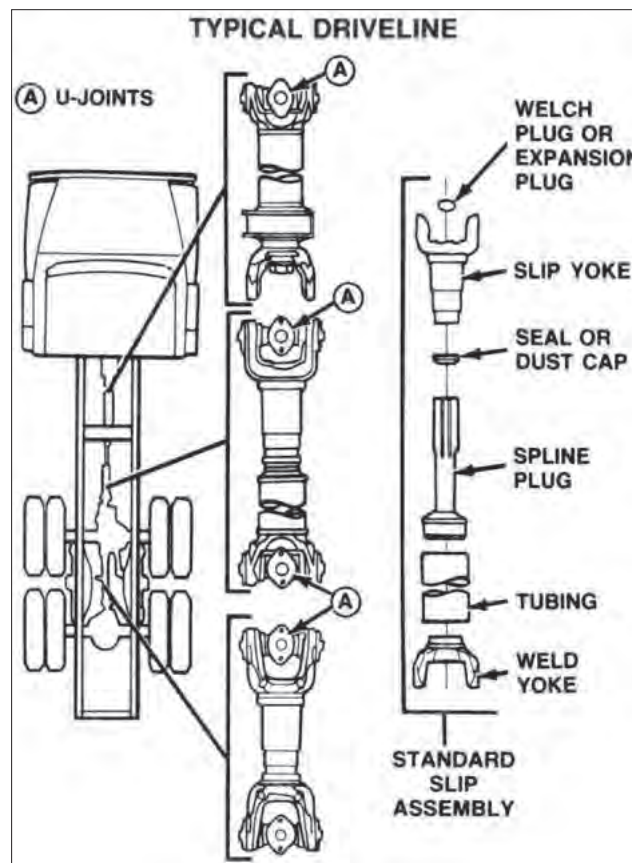

# Aftermarket Getting Technical



**MERITOR**

September 2014

## The Full-Time Part Universal Joints

A universal joint must be able to deliver brute power and high torque from a big diesel engine (or a large displacement gasoline power plant) into a rear axle (or axles) in order to drive a fully loaded truck for long distances. And all that horsepower, torque and payload hooked up to an expensive rig isn't going to deliver the load if these U-joints fail. Remember, downtime, regardless of payload or destination, is extremely costly to independent truckers and of course all trucking companies. Be aware that U-joints work **full time** every kilometre driven ... and they are an important operating member of the entire drivetrain.

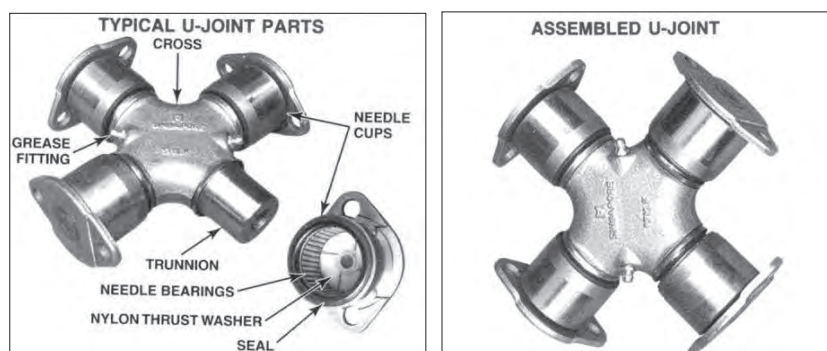

## Uni Joint Problems: Causes, Conditions And Clues

There are two U-joint problems that can develop, especially those found to be major causes of driveline failures. These 'causes' generally fall into two categories: 1) **Premature Failure** and 2) **Normal Wear** (eventually leading to the need for replacement)

**Premature Failure:** also known as '**Shock**' or '**Ultimate Failure**'

One of the most common causes of driveline failure is **Structural Overload**, also known as shock or ultimate failure. This unexpected damage occurs when the U-joint or any other part of the driveline receives a sudden, hard shock that is far more severe than what it was expected to handle. As a result, the part either ends up bent, twisted or broken. You can easily spot this type of damage by 'eyeballing' the entire length of the driveline. If you detect such damage, inspect **all** of the parts that transmit power to the drive wheels. You may find additional damage has occurred. Generally, this condition is caused by a driver who 'revs' the engine up to a high RPM and then lets the clutch engage suddenly. That's true 'shock'.

## How To Identify Structural 'Shock' - Overload Failures

**Tube Damage:** Usually, one of the hollow shafts (either a coupling, main or interaxle) is the first part of the driveline to 'let go' under the strain of a severe structural overload condition. Twisted tubing is your clue to a failure caused by a load placed on the part that far exceeds its expected capacity.

**Cross Damage:** This is the result of a severe structural overload condition. This excessively high shock load often causes U-joint crosses to crack. At times, they will break off completely.

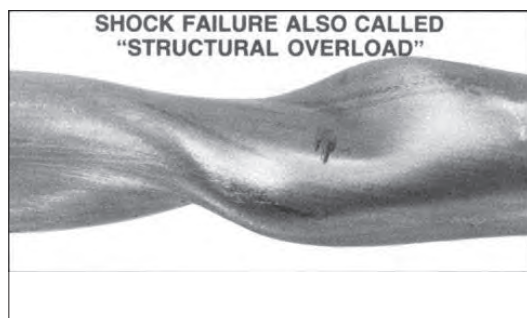

# Aftermarket Getting Technical



**MERITOR**

September 2014

## How To Identify Structural 'Shock' - Overload Failures (continued):

**Spline Plug Damage:** Another clue to excessive overloading of the driveline is a spline plug completely broken across its entire cross section. There are three types of 'break' to look for:

**Combination Bending And Twisting:** This common kind of damage is easy to identify since the excessive shock generally results in a rough surface on the face of the break, and it's usually at an angle across the spline plug.

**Twisting (also called Torsional):** You can easily detect this kind of break because the shock load that has caused the damage usually results in a smooth, flat surface failure. Basically, the shock exceeded the capability of the part.

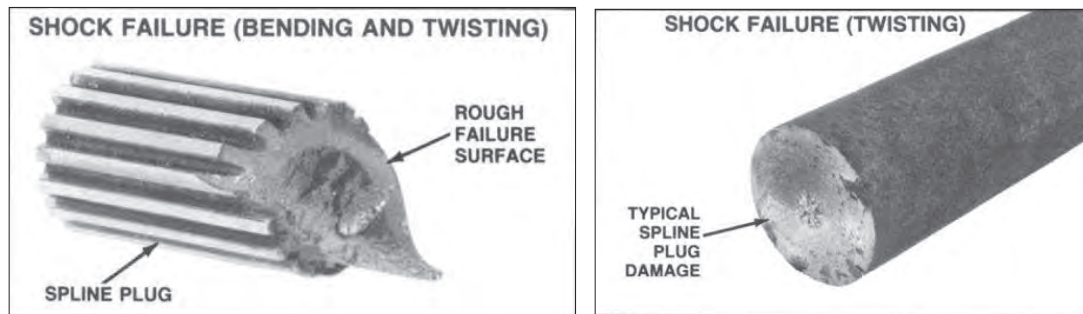

**Yoke Damage:** Since the yoke is generally the strongest part of the entire driveline, it is generally the least likely to crack and break. However, an excessively severe structural overload can cause breakage or distortion. Yoke hole alignment should always be checked whenever there is any indication of severe shock loads.

**Note: Parts get old and tired from normal wear.** Keep in mind that parts in the driveline must operate under tough driving conditions day after day, kilometre after kilometre. Under critical road operating conditions, parts get battered from the constant torque and power they must deliver. Also, wear on critical surfaces is a normal and expected process.

**Overload vs. Fatigue:** There's a quick way to compare Structural Overload to Structural Fatigue. Consider structural overload (shock) failure as the sudden snapping and breaking of a match stick. You can also compare Structural Fatigue to the flexing of a wire coat hanger. It takes repeated bending back and forth before the metal finally cracks and breaks.

## Causes Of Structural Fatigue

This type of failure will occur when driveline parts must operate under continuous long term 'high' load conditions that are far above their endurance limits. Going beyond the 'endurance limit' simply means that the maximum operating load on the part (or parts) is greater than what it was rated to handle. Such a condition must happen time after time before the part finally weakens and fails completely. We'd also like to point out that none of those "high" loads, by themselves, are ever so severe that they cause an immediate shock failure. As mentioned, it takes repeated high loads over an extended period of time before failure occurs.

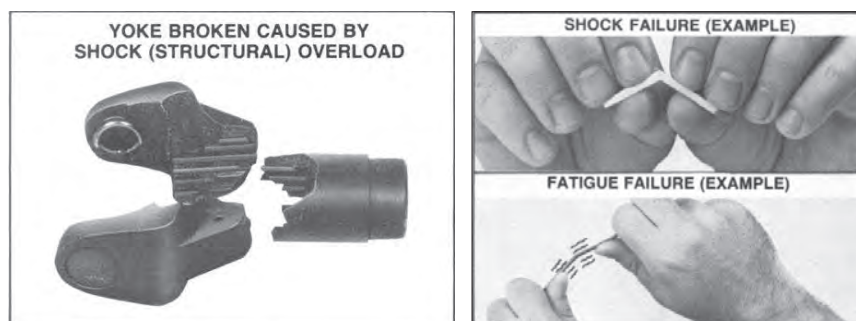

Next Edition: Identifying Structural Fatigue

# Aftermarket Special Notices



**MERITOR**

September 2014

## EUCLID TURNS 75!

Building the most trusted name in truck parts started with one man's uncompromising ideals.

In 1939, Zygmunt Zukowski founded Euclid Industries with keen attention to every engineering detail. Over the years, the building of trust continued with a relentless drive for perfection at every stage—in catalogues, in filling customer orders, in expert service, support and caring for the customer.

Earning trust every day means more quality control, inspections and more sensitivity to the needs of customers. That's why the Euclid brand has grown to become a respectable truck aftermarket brand in the North American and Australian/New Zealand markets. In January of 1999, Euclid officially became part of Meritor. Through all the changes, our principles have remained the same. Today, Euclid provides the world with precision engineered light to medium and heavy duty truck, trailer, and bus replacement parts that meet and often exceed OEM quality specification standards.

So when warehouse distributors and fleet owners see the familiar yellow box from Euclid, they know they're getting far more than ordinary replacement parts. They're getting the best replacement parts made today from a company they can trust. A company that's constantly improving with technology to do a job the only way it knows how. The Right Way. It's a philosophy that will continue to guide us for the years ahead.

Worldwide, we're committed more than ever to maintaining a tight control over quality in engineering, sales, personalised service, customer support and product training. We will continue to make improvements and add advanced systems.

Products available under the Euclid program include Air Brake Parts, Air Springs, Air Systems, Cargo Restraints, Front Axles, Hubs and Drums, Hydraulic Brake Parts, Suspension Parts and Wheel-End Components.

Meritor is doing everything possible to provide our customers with the best truck parts, when and where they're needed. 🚛

